

MLT *NEW AG* RANGE
Agricultural telehandlers



Handling your world

Founded over 60 years ago by the Braud family, the Manitou Group now operates worldwide. A world-leader in all-terrain material handling, the Group designs, manufactures, distributes and services equipment for construction, agriculture and industries.

The Group's product ranges include: all-terrain fixed, rotating and heavy-load telehandlers; all-terrain, semi-industrial and industrial masted forklift trucks; wheel or track skid-steer loaders; articulate loaders; access platforms; truck-mounted forklifts; warehousing equipment; and attachments.

Through its iconic brands - Manitou, Gehl and Mustang - and its worldwide network of 1,050 dealers, the Group offers the best solutions to create optimum value for its customers.

Headquartered in France, the Group registered a revenue in 2020 of 1.6 billion euros in 140 countries and employs 4,400 people, all strongly focused on satisfying customers.



1958

Marcel Braud conceives the idea of the Manitou truck.

1972

The Group enters foreign markets.

Sales partnership agreement signed with Toyota for exclusive distribution of Toyota industrial forklift trucks in France.

1981

Launch of first Manitou telehandler.

1984

Manitou enters the stock exchange.

1993

The first MRT rotating telehandlers are sold.

1995

Launch of the first range of access platforms.

1996

ISO 9001 certification obtained.

1998

Marcel Braud becomes Chairman of the Supervisory Board.

2006

Manitou passes the 1 billion euros sales milestone.

2007

Manitou achieves an international sales milestone of 22,000 units.



3 brands

distributed by
1,050 dealers
in 140 countries



- 30 subsidiaries
- 9 production facilities
- 4,400 employees worldwide
- 65% of the share capital held by the founding families
- 78% of revenue comes from foreign markets
- 1.6 billion euros of turnover in 2020

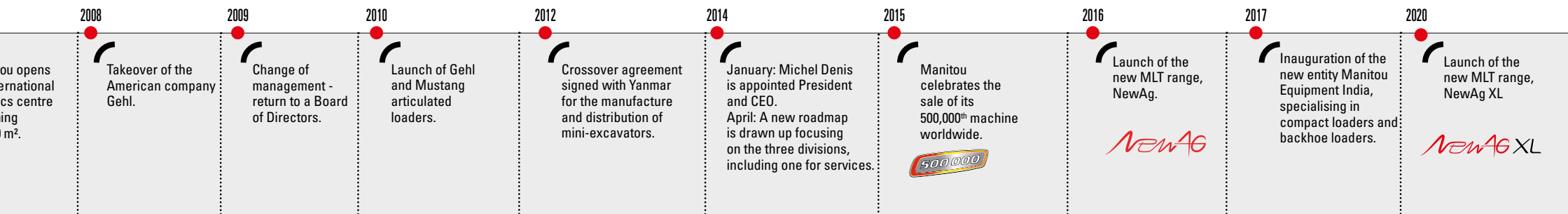

NewAg

The range of Manitou agricultural telehandlers, NewAg, was designed to assist in all your activities and to meet the needs that you express by every day.

Because your profession is demanding and essential, the NewAg range focuses on **comfort, performance and cost efficiency**. Discover what we have done for you.



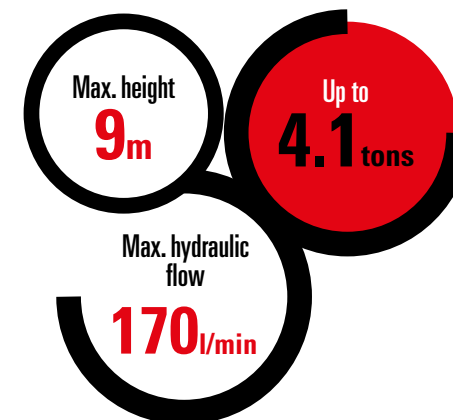

- High visibility windscreen
- Cab access with an "Easy step"
- Full-comfort cab: Harmony or Vision* screen, your choice of position for "DSB" buttons, a number of storage compartments...
- Joystick Switch and Move (JSM®) on floating armrest
- JSM® Autopower*
- Engine power*: 116, 129, 136 hp
- Emission standards: Stage V / Final Tier 4
- Auto reversing fan*
- Several types of transmissions*: torque converter (with Powershuttle or Powershift Plus gearbox), M-Varioshift, M-Vario Plus
- High-speed simultaneous movements thanks to flow sharing distributor*
- Hydraulic options*: Intelligent Hydraulics, Regenerative Hydraulics...
- Large range of original attachments approved by Manitou
- Easy Connect System (ECS)
- Several available towing hooks
- Large choice of tyres
- Centralized position of greasing points
- Connected machine

*Depending on models and/or versions.



A redesigned visibility

COMFORT **- 360° VISIBILITY**

The NewAg models feature exceptional visibility. The angle of each blade of the roof grid has been meticulously adjusted in relation to the lifting height to offer you a clear view of the load, regardless of its position.

The low position of the boom articulation point and the one-piece windshield offer you 360° visibility, guaranteeing your safety and the safety of those around you.

A cut-out section has been added at the front of the windshield to optimise your visibility when changing attachments.

The curved rear window gives greater visibility over your trailer.

Optimal lighting

Your machine is equipped to work both day and night with optimal visibility:

- Full road lighting,
- Rotating beacon light,
- 4 work lights on cab (halogen or LED*),
- 1 ceiling light,
- 2 LED boom work lights (option),
- LED+ lateral work lights (option),
- LED front road lights (option).

*Standard or optional, depending on the level of finish.



PATENTED
GRID



Global management, total visibility

Manitou offers a range of financing solutions to help you implement your projects. Own your machine immediately or at the end of the contract, with pay-as-you-use and leasing options. Contact our network of dealers to create your tailored solution.

Thanks to the extended warranty, your machine is covered for parts and labour for up to six years or 6,000 hours. You can depend on our network of expert technicians and our original spare parts - available all over the world.

With a maintenance contract, you are assured of dependable, first-rate service. Your maintenance budget is predictable and straightforward, with no unexpected costs. Your machine will be worth more when it comes to selling it.

We are always here to help make your life easier.



COMFORT DESIGN DEDICATED TO YOUR WELL BEING

Timelies when you're working in your machine!

Enjoy equipment perfectly suited to your needs: a cloth covered seat, a steering column with adjustable height and depth, a sun visor, an electric window, a USB slot, a 12V plug, a car radio, a phone holder, a cup holder, an automatic parking brake*, etc. For additional comfort, your personal belongings may easily be stowed away in any of the many spacious storage compartments.

Clear, modular dashboard

Behind the wheel of the NewAg, all the controls are within reach and are clearly identified with symbols and colour codes. And because everyone has their own way of doing things, you can choose the position of your "DSB" buttons: an essential time-saver that enables you to concentrate on the work at hand!

Easy-access cab

The non-slippery Easy step and large handles on the cab frame make it even easier to get in and out.

Lighting under the door as standard makes access to the cab safe for all users, day or night.

*Standard, except on MLT 630 and MLT 730.



Flash the video Easy step





Flash the video JSM

Manitou works hard to make your workday easier!

Exclusive to Manitou, the JSM® on the floating armrest allows safe, fatigue free operation. Each movement can be carried out with one hand including : forwards / reverse, raising and lowering of the boom, boom extension / retraction, tilt / crowd and hydraulic operations on the attachment. One hand stays on the wheel so you keep total control over your machine.

- ① FNR (Front Neutral Reverse) button
- ② Hydraulic attachment line
- ③ Telescope: retraction and extension



Forward: the boom lowers
 Backward: the boom lifts
 Left: crowd
 Right: dump

JSM® Autopower*

The autopower function automatically adjusts the engine speed according to the joystick movements operated by the driver's hand. Fuel consumption is reduced and movements become smoother for the operator.

*Standard with the M-Vario Plus transmission. Optional with M-Varioshift transmission (together with the flow sharing option).



THE CORRECT ENGINE POWER = OPTIMIZED FUEL CONSUMPTION



Engine power suited to your needs

Each telehandler has the right engine/machine combination for maximum efficiency and minimal fuel consumption.

The NewAg range is equipped with Deutz 4-cylinder engines with a cubic capacity of 3.6 l. With power ranging from 116 hp to 136 hp according to the model, these engines are perfectly suited to your activities.

A cleaner engine

In compliance with the Stage V (Final Tier 4), all NewAg models feature an EGR (Exhaust Gas Recirculation), a DOC (Diesel Oxidation Catalyst) valve, a DPF (Diesel Particulate Filter) and a SCR (Selective Catalytic Reduction) with diesel exhaust fluid (AdBlue® or similar).





10 €/HOUR
SAVINGS
WITH
ECOSTOP**

A cooling system engineered to your needs!

Your machine's electronic adjustment system* automatically manages the rotation speed of the fan according to the engine temperature. Your fuel consumption is significantly reduced.

Machine designed for dusty environments

The "auto reversing fan"* feature reverses the air flow every three minutes (for 15 seconds) regardless of the engine speed. Cooling is always optimal, even in dusty environments containing straw or chicken manure.

Reduce your fuel consumption and the number of hours of your machine

The Ecostop option allows substantial savings by shutting off the engine automatically when idling and when the driver is not in the telehandler.

*In option on MLT 733. In standard on other models.

**For 1h of use at idle speed, without driver in cab.



A VARIETY OF TRANSMISSIONS FOR A VARIETY OF TASKS

Torque converter with Powershuttle gearbox

Reliable, economic and effective, this transmission is particularly well-suited if you use the machine for tasks such as agricultural loading and off-road or on-road transport. Combined with a four-speed manual gearbox, it allows you to easily adapt your speed to the work at hand.

Torque converter with Powershift Plus gearbox

This transmission is very easy to use. Gears can be changed on the move maintaining constant torque. Simply press the +/- buttons on the JSM® joystick to go through the 6 gears or use the automatic mode.



Inching* feature

This function allows you to speed up the boom's movements as you gradually reduce the telehandler's forward speed.

Eco* mode

The engine speed is optimized while guaranteeing high performances. Fuel consumption and sound pollution are greatly reduced.



Up to
40 km/h

M-Varioshift

Choose your speed with a simple movement directly from the JSM® (+/- buttons). Precision and tractive power: the M-Varioshift guarantees smooth handling.

M-Vario Plus

Yes it is possible to get up to 40 kph smoothly and without changing gear!

This continuous variable transmission (CVT) consists of two hydraulic motors powered by a hydraulic pump.

At low speeds, the two motors are active. The tractive power is therefore comparable to that of a torque converter transmission. At high speeds, only one motor is active. Fuel consumption is optimized and the sound pollution caused by the transmission is reduced.

The M-Vario Plus combines precision and performance and is a pleasure to use, even for the most inexperienced users.

MLT 635 + CBA bucket

*Standard with M-Varioshift and M-Vario Plus transmissions.

2 operating* modes

- **“Comfort” mode**

For more precise operations.

This mode is perfect for placing loads.

- **“Dynamic” mode**

Your MLT will be more responsive during loading operations.



PERFORMANCE CREATE FREE TIME FOR OTHER TASKS...

Fast and simultaneous hydraulic movements

Combined with the JSM[®], the hydraulic pump of your MLT delivers a maximum flow of 104, 106, 150 or 170 l/min for fast and precise work. The flow sharing* distributor enables combined movements for more efficiency.

The Intelligent Hydraulics**option package (quick lift, bucket shaker, return to load) makes the difference. This allows several hydraulic functions to be automated.



Flash the video Intelligent Hydraulics

*Optional on MLT 630, MLT 730 and MLT 733.
**Not available on MLT 630, MLT 730 and MLT 733.





MLT 737 + SHG shear grab bucket

Attachments can be changed **in seconds**

With the Manitou attachment carriage, which has equipped our telehandler models for 35 years, attachments can be changed within seconds.

The ECS® (Easy Connect System) decompresses the hydraulic attachment line, making it quick and easy to change your hydraulic attachments.

To save even more time, the attachment hydraulic locking allows a non-hydraulic attachment to be changed and secured without having to leave the machine.

Time and **money savings**

The Regenerative Hydraulics* system makes it possible to lower the boom, regardless of engine speed, using gravitational force. Save time and fuel consumption.

*Not available on MLT 630, MLT 730 and MLT 733.

PERFORMANCE MANOEUVRABLE ON ALL TERRAINS



All-terrain handling

- Agricultural profile tires
- High ground clearance making it possible to easily clear obstacles
- Oscillating rear axles to maintain maximum grip and stability
- Four wheel drive
- Limited slip differential on the front axle for easy navigation on difficult terrains
- Active CRC boom suspension (optional), absorbs unintentional movements of the boom
- Optimal turning radius
- Dimensions suitable for agricultural use with a varied range of heights and widths available



A choice of four steering modes

An ultra-manoeuverable machine with four steering modes:

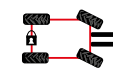

Front wheel steer
for road travel,

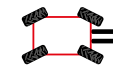

4 wheel steer
for manoeuvring in space-restricted work sites,

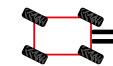

Crab mode
for sideways approaches and tricky unloading manoeuvres,

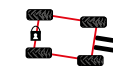

Manicrab mode
for tasks such as silage making.

PERFORMANCE DESIGNED TO LAST

1. A “double U shaped” boom, welded along the centre, positioned where there is the least amount of strain. Ideal for tough working conditions.
2. Hoses and distributor are protected under the boom.
3. Tilt ram protected behind the boom head.
4. Dana Spicer axles with epicyclic reduction gears.
5. Steering cylinders in a raised position, protected from gravel splatter.
6. Multiple-disk oil-bath brakes within axles.
7. Possibility to change the position of the rear mounted mirror at the back of the machine to avoid breakage risks.
8. Monobloc chassis.
9. Cab compliant with ROPS / FOPS level 2 standards.



COST EFFICIENCY OUR PRIORITY: MAKING YOUR LIFE EASIER

Easy access to the main engine components

The wide opening of the engine cover on the side of the machine allows easy access to the main components.

... but there is more

- Access hatch (beneath the radiator)
- Self cleaning air prefilter
- Fuel, hydraulic oil and AdBlue tanks clearly identified to avoid the risk of errors
- Centralised greasing points
- Automatic Greasing System (AGS) option
- Optimisation of maintenance intervals: hydraulic oil change every 2000 hrs and air filter change every 1000 hrs
- Removable plate at the rear of the boom



Efficient maintenance

Service intervals and fault codes are displayed on the dashboard screen. Machine connectivity allows you to share information with your dealer for a more rapid response, with problems resolved on the first visit. You save time and money!



A connected machine

Remain in control of your machine at all times!

With the help of a mobile application, you can monitor your machine's performance in real time and facilitate your day-to-day operations.

Share your data with maintenance professionals to receive remote advice or to organise technical intervention and thus reduce downtime.

Thanks to the alerts and the proactive approach, you will be able to carry out your material handling with total peace of mind.



Our commitment to you

Our teams are committed to providing innovative solutions and continuous improvements to reduce the total cost of ownership* of your machine. Find simple online calculation tools to assess your own TCO*:

- Identify your direct and indirect costs.
- Make the right choice by considering the performance parameters and service available to you.
- Improve the resale value of your machine.
- Calculate your fuel consumption.
- View more than 300 tutorial videos and a range of technical documentation.

To make the right decisions - try the <http://www.reduce-program.com> calculator and follow the tips and advice.

*What is the TCO? The Total Cost of Ownership is a calculation of running costs. The TCO takes into account fixed costs, such as acquisition, financing, residual value, etc., and the variable costs linked to the use of your machine, such as maintenance, energy consumption, user training, etc.



"Since my dealer has been managing the maintenance of my machine, he contacts me proactively to plan my next appointments with a technician on my farm, at a time that's convenient for me. It gives me real peace of mind so I can concentrate on my day-to-day work, my livestock and my crops".

Romain, 29, Farmer







TO EACH HIS OWN... STYLE

Choose from a wide range of telehandlers with a capacity ranging from 3 to 4.1 tonnes and a lifting height ranging from 6 to 9 metres. You also have the choice among various options and finish levels to best suit your needs.



MLT 630-115 V CP

Transmission*	H/C/CVT	H
Engine Power	hp (kW)	116/85
Engine brand	-	Deutz
Engine norm	-	Stage V
Max. capacity	kg	3000
Max. lifting height	m	6.00
Max. reach	m	3.43
Dimensions without attachments (LxWxH)	m	4.78x2.06x2.14
Hydraulics	l/min	106
Unladen weight with forks	kg	6640
Speed	km/h	38

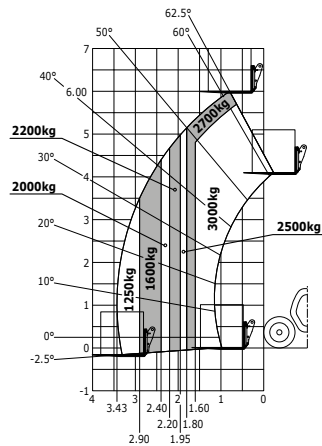

All terrain load chart (EN 1459 B)



MLT 630-115 V

Transmission*	H/C/CVT	H
Engine Power	hp (kW)	116/85
Engine brand	-	Deutz
Engine norm	-	Stage V
Max. capacity	kg	3000
Max. lifting height	m	6.10
Max. reach	m	3.34
Dimensions without attachments (LxWxH)	m	4.78x2.13x2.34
Hydraulics	l/min	106
Unladen weight with forks	kg	6960
Speed	km/h	40



All terrain load chart (EN 1459 B)



MLT 630-115

Transmission*	H/C/CVT	C
Engine Power	hp (kW)	116/85
Engine brand	-	Deutz
Engine norm	-	Stage V
Max. capacity	kg	3000
Max. lifting height	m	6.10
Max. reach	m	3.34
Dimensions without attachments (LxWxH)	m	4.78x2.13x2.34
Hydraulics	l/min	106
Unladen weight with forks	kg	7010
Speed	km/h	40

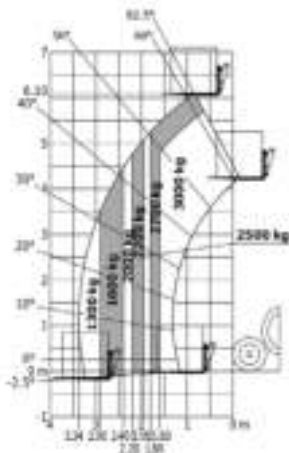

All terrain load chart (EN 1459 B)



MLT 730-115 V CP

Transmission*	H/C/CVT	H
Engine Power	hp (kW)	116/85
Engine brand	-	Deutz
Engine norm	-	Stage V
Max. capacity	kg	3000
Max. lifting height	m	6.75
Max. reach	m	4.35
Dimensions without attachments (LxWxH)	m	5.08x2.06x2.14
Hydraulics	l/min	106
Unladen weight with forks	kg	6820
Speed	km/h	38

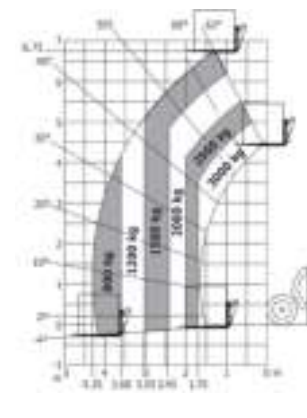

All terrain load chart (EN 1459 B)

* H: Hydrostatic
C: Torque converter
CVT: Continuous Variable Transmission



MLT 730-115 V

Transmission*	H/C/CVT	H
Engine Power	hp (kW)	116/85
Engine brand	-	Deutz
Engine norm	-	Stage V
Max. capacity	kg	3000
Max. lifting height	m	6.90
Max. reach	m	4.25
Dimensions without attachments (LxWxH)	m	5.08x2.13x2.34
Hydraulics	l/min	106
Unladen weight with forks	kg	7140
Speed	km/h	40

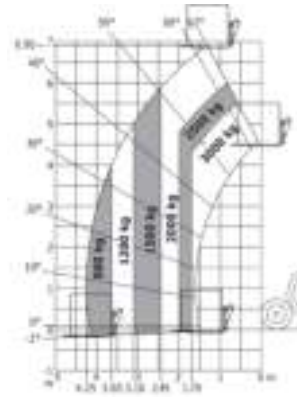

All terrain load chart (EN 1459 B)



MLT 635-130 PS+

Transmission*	H/C/CVT	C
Engine Power	hp (kW)	129/95
Engine brand	-	Deutz
Engine norm	-	Stage V
Max. capacity	kg	3500
Max. lifting height	m	6.08
Max. reach	m	3.20
Dimensions without attachments (LxWxH)	m	4.66x2.39x2.38
Hydraulics	l/min	150
Unladen weight with forks	kg	7606
Speed	km/h	40

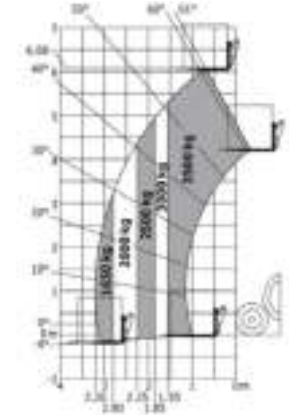

All terrain load chart (EN 1459 B)



MLT 635-140 V+

Transmission*	H/C/CVT	CVT
Engine Power	hp (kW)	136/100
Engine brand	-	Deutz
Engine norm	-	Stage V
Max. capacity	kg	3500
Max. lifting height	m	6.08
Max. reach	m	3.20
Dimensions without attachments (LxWxH)	m	4.66x2.39x2.38
Hydraulics	l/min	170
Unladen weight with forks	kg	7600
Speed	km/h	40

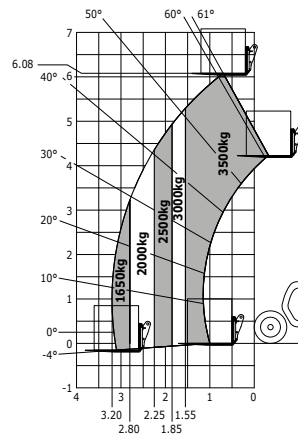

All terrain load chart (EN 1459 B)



MLT 733-115 / LSU

Transmission*	H/C/CVT	C
Engine Power	hp (kW)	116/85
Engine brand	-	Deutz
Engine norm	-	Stage V
Max. capacity	kg	3300
Max. lifting height	m	6.90
Max. reach	m	3.90
Dimensions without attachments (LxWxH)	m	4.78x2.39x2.38 4.85x2.39x2.38**
Hydraulics	l/min	104/150**
Unladen weight with forks	kg	7120
Speed	km/h	33

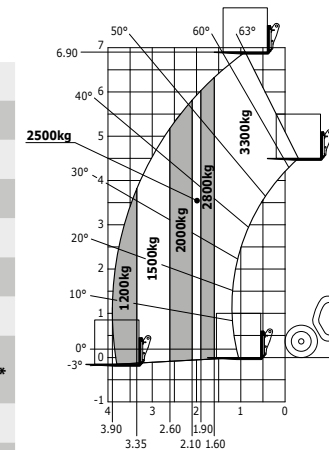

All terrain load chart (EN 1459 B)

* H: Hydrostatic
C: Torque converter
CVT: Continuous Variable Transmission

** with LS pump



MLT 737-130 PS+

Transmission*	H/C/CVT	C
Engine Power	hp (kW)	129/95
Engine brand	-	Deutz
Engine norm	-	Stage V
Max. capacity	kg	3700
Max. lifting height	m	6.90
Max. reach	m	3.90
Dimensions without attachments (LxWxH)	m	4.97x2.39x2.38
Hydraulics	l/min	150
Unladen weight with forks	kg	7650
Speed	km/h	40

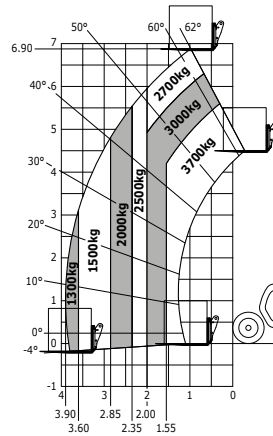

All terrain load chart (EN 1459 B)



MLT 741-130 PS+

Transmission*	H/C/CVT	C
Engine Power	hp (kW)	129/95
Engine brand	-	Deutz
Engine norm	-	Stage V
Max. capacity	kg	4100
Max. lifting height	m	6.90
Max. reach	m	3.90
Dimensions without attachments (LxWxH)	m	4.97x2.39x2.38
Hydraulics	l/min	150
Unladen weight with forks	kg	7965
Speed	km/h	40

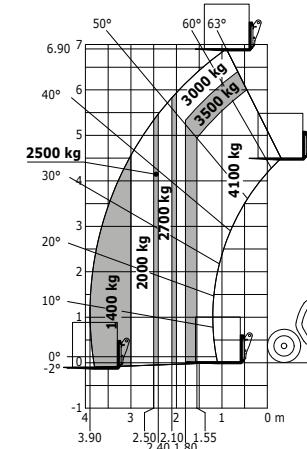

All terrain load chart (EN 1459 B)



MLT 741-140 V+

Transmission*	H/C/CVT	CVT
Engine Power	hp (kW)	136/100
Engine brand	-	Deutz
Engine norm	-	Stage V
Max. capacity	kg	4100
Max. lifting height	m	6.90
Max. reach	m	3.90
Dimensions without attachments (LxWxH)	m	4.97x2.39x2.38
Hydraulics	l/min	170
Unladen weight with forks	kg	7755
Speed	km/h	40

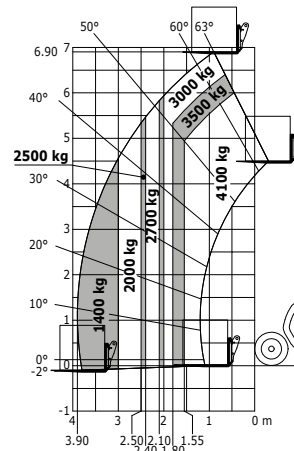

All terrain load chart (EN 1459 B)



MLT 940-140 V+

Transmission*	H/C/CVT	CVT
Engine Power	hp (kW)	136/100
Engine brand	-	Deutz
Engine norm	-	Stage V
Max. capacity	kg	4000
Max. lifting height	m	9.00
Max. reach	m	6.55
Dimensions without attachments (LxWxH)	m	5.12x2.39x2.38
Hydraulics	l/min	170
Unladen weight with forks	kg	8361
Speed	km/h	40

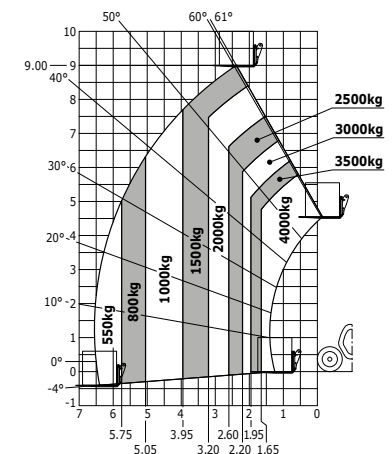

All terrain load chart (EN 1459 B)

* H: Hydrostatic
C: Torque converter
CVT: Continuous Variable Transmission

3 finish levels available



s : standard / o : option / - : not available

	MLT 630 V CP			MLT 630 V			MLT 630			MLT 730 V CP			MLT 730 V			MLT 635 PS+/V+			MLT 733			MLT 737 PS+			MLT 741 PS+/V+			MLT 940 V+					
Chassis																																	
Automatic wheel alignment	o	o	s	o	o	s	o	o	s	o	o	s	o	o	s	o	o	s	-	-	o	o	s	o	o	s	o	o	s	o	o	s	
Additional fuel tank (39l)	o	s	s	o	s	s	o	s	s	o	s	s	o	s	s	-	-	-	-	-	-	-	-	-	-	-	-	-	-	-	-	-	
Manual rotating towing hitch	s	s	s	s	s	s	s	s	s	s	s	s	s	s	s	s	s	s	-/s	-/s	s	s	s	s	s	s	s	s	s	s	s	s	
Automatic rotating towing hitch	o	o	o	o	o	o	o	o	o	o	o	o	o	o	o	o	o	o	-/o	-/o	o	o	o	o	o	o	o	o	o	o	o	o	
Ladder hitch	o	o	o	o	o	o	o	o	o	o	o	o	o	o	o	o	o	o	o	o	o	o	o	o	o	o	o	o	o	o	o	o	
Hydraulic "pick-up hitch"	o	o	o	o	o	o	o	o	o	o	o	o	o	o	o	o	o	o	o	o	o	o	o	o	o	o	o	o	o	o	o	o	
Operator station																																	
Mechanical cloth-covered seat (GRAMMER)	s	-	-	s	-	-	s	-	-	s	-	-	s	-	-	s	-	-	s	-	s	-	-	s	-	-	s	-	-	s	-	-	
Air suspension cloth-covered seat (GRAMMER)	o	s	-	o	s	-	o	s	-	o	s	-	o	s	-	o	s	-	o	s	o	s	-	o	s	-	o	s	-	o	s	-	
Low frequency air suspension cloth-covered seat (GRAMMER)	o	o	s	o	o	s	o	o	s	o	o	s	o	o	s	o	o	s	o	o	o	o	s	o	o	s	o	o	s	o	o	s	
Tuner car radio (50W)	s	-	-	s	-	-	s	-	-	s	-	-	s	-	-	s	-	-	s	-	s	-	-	s	-	-	s	-	-	s	-	-	
Bluetooth USB car radio with integrated microphone (100 W)	o	s	-	o	s	-	o	s	-	o	s	-	o	s	-	o	s	-	o	s	o	s	-	o	s	-	o	s	-	o	s	-	
Bluetooth USB car radio with extra microphone (100 W)	o	o	s	o	o	s	o	o	s	o	o	s	o	o	s	o	o	s	o	o	o	o	s	o	o	s	o	o	s	o	o	s	
Manual air conditioning	o	s	-	o	s	-	o	s	-	o	s	-	o	s	-	o	s	-	o	s	o	s	-	o	s	-	o	s	-	o	s	-	
Air conditioning with automatic adjustment	o	o	s	o	o	s	o	o	s	o	o	s	o	o	s	o	o	s	o	o	o	o	s	o	o	s	o	o	s	o	o	s	
Harmony screen	s	s	-	s	s	-	s	s	-	s	s	-	s	s	-	s	s	-	s	s	s	s	-	s	s	-	s	s	-	s	s	-	
Vision screen (7")	o	o	s	o	o	s	o	o	s	o	o	s	o	o	s	o	o	s	-	-	o	o	s	o	o	s	o	o	s	o	o	s	
Lighting																																	
Front and rear work lights on cab (x4)	s	-	-	s	-	-	s	-	-	s	-	-	s	-	-	s	-	-	s	-	s	-	-	s	-	-	s	-	-	s	-	-	
Front and rear LED work lights on cab (x4)	o	s	s	o	s	s	o	s	s	o	s	s	o	s	s	o	s	s	o	s	o	s	s	o	s	s	o	s	s	o	s	s	
LED + (4 extra work lights)	o	o	o	o	o	o	o	o	o	o	o	o	o	o	o	o	o	o	-	-	o	o	o	o	o	o	o	o	o	o	o	o	
LED boom work lights (on fixed part) (x2)	o	o	o	o	o	o	o	o	o	o	o	o	o	o	o	o	o	o	o	o	o	o	o	o	o	o	o	o	o	o	o	o	
Boom																																	
Easy Connect System (ECS)	s	s	s	s	s	s	s	s	s	s	s	s	s	s	s	s	s	s	s	s	s	s	s	s	s	s	s	s	s	s	s	s	
Attachment hydraulic locking	o	o	o	o	o	o	o	o	o	o	o	o	o	o	o	o	o	o	o	o	o	o	o	o	o	o	o	o	o	o	o	o	
"Active CRC" boom suspension	o	o	s	o	o	s	o	o	s	o	o	s	o	o	s	o	o	s	o	o	o	o	s	o	o	s	o	o	s	o	o	s	
Electrovalve for 2 hydraulic functions on boom head	o	o	o	o	o	o	o	o	o	o	o	o	o	o	o	o	o	o	o	o	o	o	o	o	o	o	o	o	o	o	o	o	
Regenerative Hydraulics	-	-	-	-	-	-	-	-	-	-	-	-	-	-	-	o	o/s	o/s	-	-	o	o	o	o	o	o/s	o/s	o	s	s	o	s	s
Intelligent Hydraulics	-	-	-	-	-	-	-	-	-	-	-	-	-	-	-	o	o	o/s	-	-	o	o	o	o	o	o/s	o	o	s	o	o	s	
Engine / Energy																																	
Continuous flow hydraulics	o	o	s	o	o	s	o	o	s	o	o	s	o	o	s	o	o	s	o	o	o	o	s	o	o	s	o	o	s	o	o	s	
Hand throttle	o	o	s	o	o	s	o	o	s	o	o	s	o	o	s	o/s	o/s	s	-	-	o	o	s	o/s	o/s	s	s	s	s	s	s	s	
Safety																																	
Extra front wiper	o	s	s	o	s	s	o	s	s	o	s	s	o	s	s	o	s	s	o	s	o	s	s	o	s	s	o	s	s	o	s	s	
Flat grid on the roof (-2 cm overall height)	o	o	o	-	-	-	-	-	-	o	o	o	-	-	-	-	-	-	-	-	-	-	-	-	-	-	-	-	-	-	-	-	
Electric mirror with de-icing	o	o	s	o	o	s	o	o	s	o	o	s	o	o	s	-	-	o	o	s	o	o	s	o	o	s	o	o	s	o	o	s	
Hydraulic trailer brake	o	o	o	o	o	o	o	o	o	o	o	o	o	o	o	o	o	o	-/o	-/o	o	o	o	o	o	o	o	o	o	o	o	o	
Air trailer brake	o	o	o	o	o	o	o	o	o	o	o	o	o	o	o	o	o	o	-	-	o	o	o	o	o	o	o	o	o	o	o	o	



Manitou, as a manufacturer of machines and attachments, is the best placed to guarantee you uncompromising performance and safety.

Discover all our attachments on manitou.com



Feed and silage

Solutions for silage cutting, preparation and distribution.



Manure loading

Handling solutions for all types of manure (heavy, straw or powdery).



Various ag applications

Bulk handling, silage cutting and/or manure handling solutions.



Handling of grain and light bulk

The essential attachment for storage of grain, fertiliser, mineral supplements, etc.



Bale handling

Wide range of solutions for handling square, round, wrapped and unwrapped bales.



General handling

Simple, effective solutions for handling palletised or non-palletised loads.



Maintenance

Sweeping and cleaning solutions for your farm maintenance.





Your nearest dealer:



Head office

B.P. 249 - 430 rue de l'Aubinière - 44158 Ancenis Cedex - France

Tel.: 00 33 (0)2 40 09 10 11 - Fax: 00 33 (0)2 40 09 10 97



This publication provides the description of the versions and configuration possibilities of Manitou products, which may differ in terms of equipment. The equipment presented in this brochure may be available as part of a series, available as an option, or not available, depending on the versions. Manitou reserves the right, at any time and without notice, to amend the specifications described and represented. The specifications provided do not bind the manufacturer. For more details, please contact your Manitou agent. This is not a contractually binding document. The presentation of the products is not contractually binding. The list of specifications is non-exhaustive. The logos and visual identity of the company are the property of Manitou and cannot be used without authorisation. All rights are reserved. The photos and diagrams in this brochure are only provided for consultation and information purposes. Manitou BF SA - Limited company with board of directors. Share capital: 39,547,824 euros - 857 802 508 RCS Nantes