

Technical sheet

CT 40

Warehousing Equipment



	Technical characteristics	Metric
1.1	Manufacturer	Manitou
1.2	Model	CT 40
1.3	Type of traction	Electric
1.4	Type of operation	Carried
1.9	y - Wheelbase	1109 mm
	Weight	
2.1	Weight of truck in working order	1270 kg
2.3	Unladen weight on front/rear axle	800 kg / 470 kg
	Wheels	
3.1	Tyre equipment: bandage (V), PPS (SE), inflatable tyre (L)	Polyurethane
3.5	Number of front wheels (x)	3 / 2
	Dimensions	
4.2	h1 - Height (mast lowered)	1210 mm
4.19	l1 - Total length	1550 mm
4.21	b1 - Overall width - Single/twin wheels	800 mm / -
4.35	Wa - Turning radius	1330 mm
	Performances	
5.5	Nominal pulling force laden / unladen	370 daN / -
5.7	Maximum ramp laden / unladen	4 % / 13 %
5.10	Service brake	Electromagnetic
	Engine	
6.4	Battery voltage/capacity	24 V / 465 Ah
7.2	Useful power	2 kW
	Miscellaneous	
8.4	Measured/guaranteed mean noise level at the ear of the operator	66 dB(A)

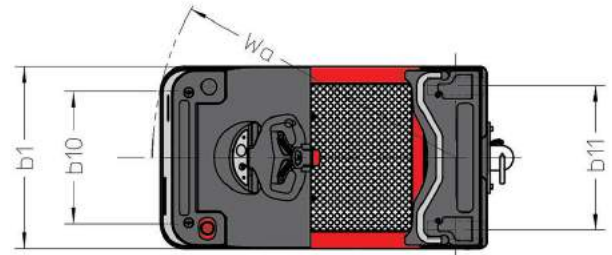
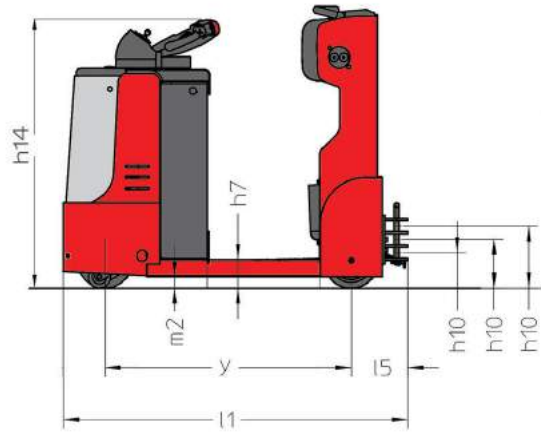



Siège Social
430 rue de l'Aubinière - 44150 Ancenis Cedex - France
Tel: +33(0)2 40 09 10 11 - Fax: +33 (0)2 40 09 10 97
www.manitou.com



This brochure describes versions and configuration options for Manitou products which may be fitted with different equipment. The equipment described in this brochure may be standard, optional or not available depending on version. Manitou reserves the right to change the specifications shown and described at any time and without prior warning. The manufacturer is not liable for the specifications given. For more information, contact your Manitou dealer. Non-contractual document. Product descriptions may differ from actual products. List of specifications is not comprehensive. The logos and visual identity of the company are the property of Manitou and may not be used without authorisation. All rights reserved. The photos and diagrams contained in this brochure are provided for information only.

MANITOU BF SA - Limited company with board of directors - Share capital: 39,547,824 euros - 857 802 508 RCS Nantes