

Technical sheet

# **EMA II 18 HL-1**

Warehousing Equipment



	Technical characteristics	Metric
1.1	Manufacturer	Manitou
1.2	Model	EMA II 18 HL-1
1.3	Type of traction	Electric
1.4	Type of operation	Seated
1.5	Q - Rated capacity	1750 kg
1.6	c - Center of gravity of load	500 mm
Weight		
2.1	Weight of truck in working order	6900 kg
2.2	Laden weight on front/rear axle	4200 kg / 4500 kg
2.3	Unladen weight on front/rear axle	2200 kg / 4700 kg
Wheels		
3.1	Tyre equipment: bandage (V), PPS (SE), inflatable tyre (L)	Cellular solid cushion
3.5	Number of front wheels (x)	2x / 2
Dimensions		
4.1	$\alpha$ / $\beta$ - Front/Rear mast angle	1.50 ° / 4 °
4.2	h1 - Height (mast lowered)	3720 mm
4.4	h3 - Lift height (Duplex mast)	5550 mm
4.5	h4 - Height of extended mast	6380 mm
4.19	l1 - Total length	3740 mm
4.20	l2 - Length to fork heel	2590 mm
4.21	b1 - Overall width - Single/twinned wheels	1250 mm / -
4.22	e / s / l - Fork dimensions	1150 x 125 x 40
4.24	b3 - Width of fork clamp	860 mm
4.33	Ast - Aisle width for 1000 x 1200 pallet widthwise	1950 mm
4.34	Ast - Aisle width for 800 x 1200 pallet lengthwise	2200 mm
Performances		
5.1	Speed of travel laden / unladen	9 km/h / 9.50 km/h
5.2	Lifting speed laden / unladen	0.35 m/s / 0.45 m/s
5.3	Lowering speed laden / unladen	0.40 m/s / 0.36 m/s
5.7	Maximum ramp laden / unladen	8 % / 10.50 %
Engine		
6.4	Battery voltage/capacity	48 V / 775 Ah
7.2	Useful power	10 kW
Miscellaneous		
8.2	Working hydraulic pressure for attachments	200 bar
8.3	Oil flow rate for attachments	25 l/min
8.4	Measured/guaranteed mean noise level at the ear of the operator	73 dB(A)

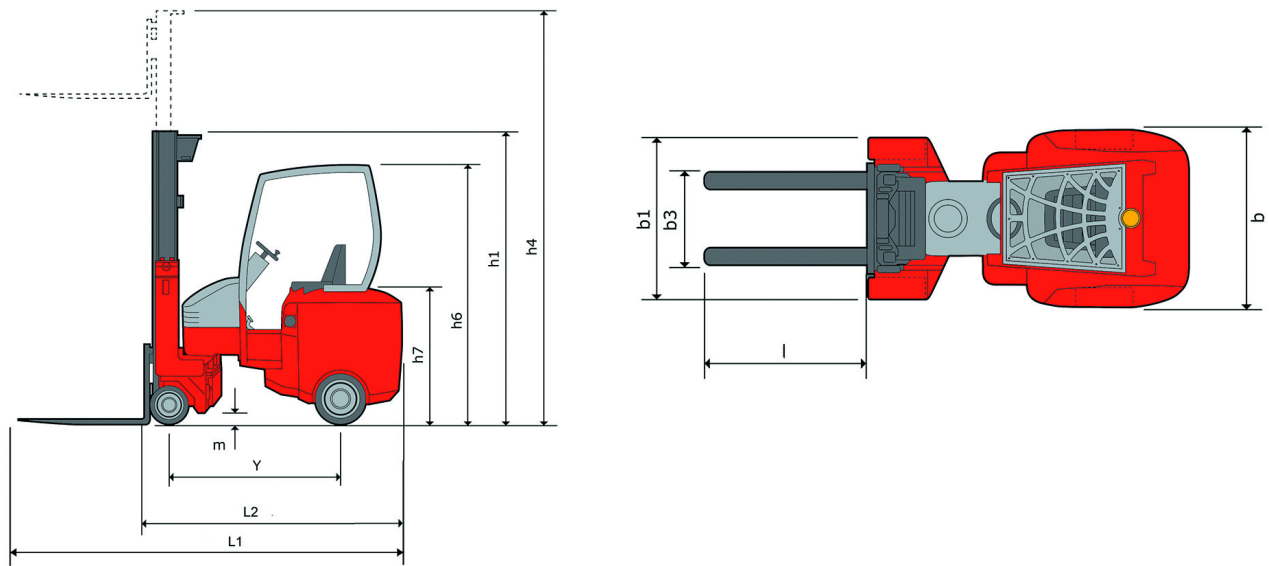

### Characteristics of masts and residual capacities

Triplex Free Lift		8010	8400	8610	9000	9500	10020	10200	10560
Lift height	mm	8010	8400	8610	9000	9500	10020	10200	10560
Height (mast lowered)	mm	3720	3900	4020	4150	4500	4590	4690	4820
Free lift	mm	2900	3080	3200	3330	3650	3770	3870	4000
Height of extended mast	mm	8840	9230	9440	9830	10475	10850	11175	11535

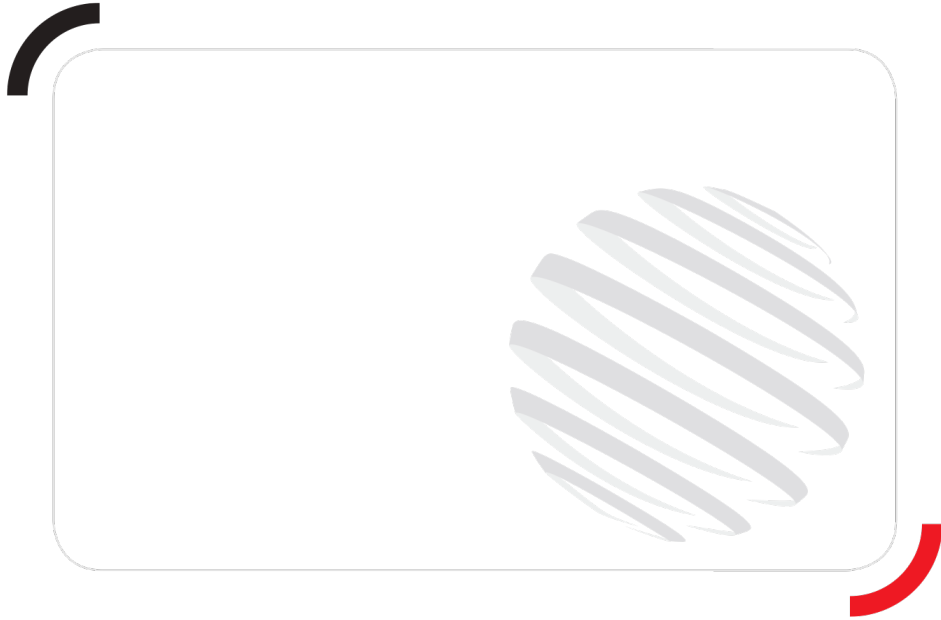

Siège Social  
430 rue de l'Aubinière - 44150 Ancenis Cedex - France  
Tel: +33(0)2 40 09 10 11 - Fax: +33 (0)2 40 09 10 97  
[www.manitou.com](http://www.manitou.com)



This brochure describes versions and configuration options for Manitou products which may be fitted with different equipment. The equipment described in this brochure may be standard, optional or not available depending on version. Manitou reserves the right to change the specifications shown and described at any time and without prior warning. The manufacturer is not liable for the specifications given. For more information, contact your Manitou dealer. Non-contractual document. Product descriptions may differ from actual products. List of specifications is not comprehensive. The logos and visual identity of the company are the property of Manitou and may not be used without authorisation. All rights reserved. The photos and diagrams contained in this brochure are provided for information only.

MANITOU BF SA - Limited company with board of directors - Share capital: 39,547,824 euros - 857 802 508 RCS Nantes

Technical sheet

# ***EMA II 18 HL-2***

Warehousing Equipment



	Technical characteristics	Metric
1.1	Manufacturer	Manitou
1.2	Model	EMA II 18 HL-2
1.3	Type of traction	Electric
1.4	Type of operation	Seated
1.5	Q - Rated capacity	1750 kg
1.6	c - Center of gravity of load	500 mm
1.9	y - Wheelbase	1745 mm
	<b>Weight</b>	
2.1	Weight of truck in working order	8700 kg
2.2	Laden weight on front/rear axle	6330 kg / 4080 kg
2.3	Unladen weight on front/rear axle	3480 kg / 5220 kg
	<b>Wheels</b>	
3.1	Tyre equipment: bandage (V), PPS (SE), inflatable tyre (L)	Cellular solid cushion
3.5	Number of front wheels (x)	2x / 2
	<b>Dimensions</b>	
4.1	$\alpha$ / $\beta$ - Front/Rear mast angle	1.50 ° / 4 °
4.2	h1 - Height (mast lowered)	3720 mm
4.4	h3 - Lift height (Duplex mast)	5550 mm
4.5	h4 - Height of extended mast	6380 mm
4.19	l1 - Total length	3740 mm
4.20	l2 - Length to fork heel	2590 mm
4.21	b1 - Overall width - Single/twinned wheels	1500 mm / -
4.22	e / s / l - Fork dimensions	1150 x 125 x 40
4.24	b3 - Width of fork clamp	860 mm
4.33	Ast - Aisle width for 1000 x 1200 pallet widthwise	2000 mm
4.34	Ast - Aisle width for 800 x 1200 pallet lengthwise	2250 mm
	<b>Performances</b>	
5.1	Speed of travel laden / unladen	9.50 km/h / 9 km/h
5.2	Lifting speed laden / unladen	0.35 m/s / 0.45 m/s
5.3	Lowering speed laden / unladen	0.40 m/s / 0.36 m/s
5.7	Maximum ramp laden / unladen	8 % / 10.50 %
	<b>Engine</b>	
6.4	Battery voltage/capacity	48 V / 930 Ah
7.2	Useful power	10 kW
	<b>Miscellaneous</b>	
8.2	Working hydraulic pressure for attachments	200 bar
8.3	Oil flow rate for attachments	25 l/min
8.4	Measured/guaranteed mean noise level at the ear of the operator	73 dB(A)

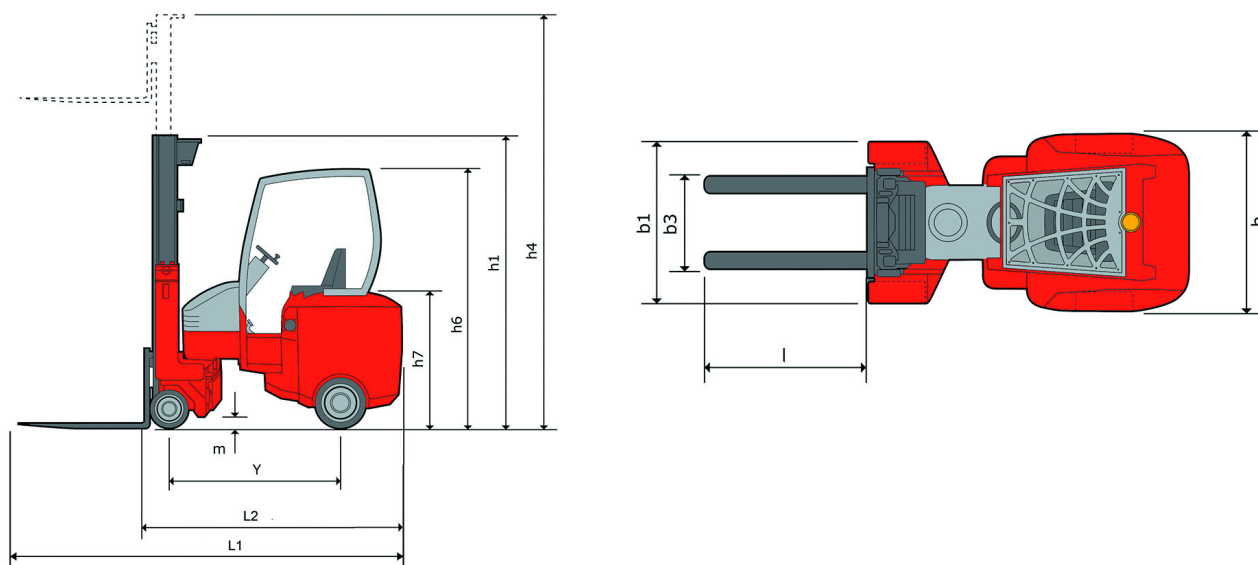

### Characteristics of masts and residual capacities

Triplex Free Lift		8010	8400	9000	9500	10020	10200	11010	12000	12510	12720
Lift height	mm	8010	8400	9000	9500	10020	10200	11010	12000	12510	12720
Height (mast lowered)	mm	3720	3900	4150	4270	4590	4690	5000	5340	5550	5570
Free lift	mm	2900	3080	3330	3650	3770	3870	4180	4520	4680	4750
Height of extended mast	mm	8840	9230	9830	10350	10850	11175	11985	13005	13485	13695

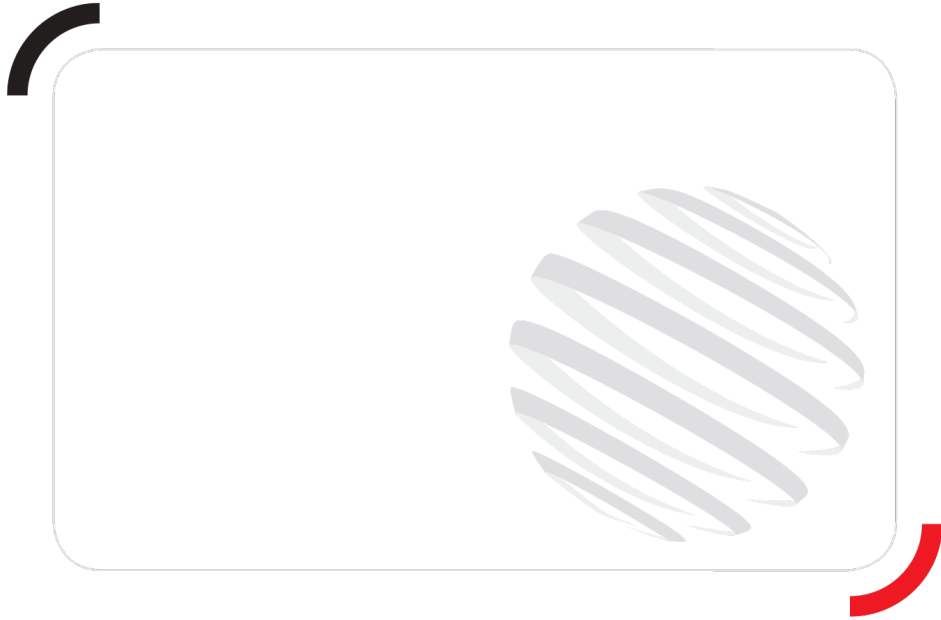

Siège Social  
430 rue de l'Aubinière - 44150 Ancenis Cedex - France  
Tel: +33(0)2 40 09 10 11 - Fax: +33 (0)2 40 09 10 97  
[www.manitou.com](http://www.manitou.com)



This brochure describes versions and configuration options for Manitou products which may be fitted with different equipment. The equipment described in this brochure may be standard, optional or not available depending on version. Manitou reserves the right to change the specifications shown and described at any time and without prior warning. The manufacturer is not liable for the specifications given. For more information, contact your Manitou dealer. Non-contractual document. Product descriptions may differ from actual products. List of specifications is not comprehensive. The logos and visual identity of the company are the property of Manitou and may not be used without authorisation. All rights reserved. The photos and diagrams contained in this brochure are provided for information only.

MANITOU BF SA - Limited company with board of directors - Share capital: 39,547,824 euros - 857 802 508 RCS Nantes