

Technical sheet

EMA II 13

Warehousing Equipment



	Technical characteristics	Metric
1.1	Manufacturer	Manitou
1.2	Model	EMA II 13
1.3	Type of traction	Electric
1.4	Type of operation	Seated
1.5	Q - Rated capacity	1300 kg
1.6	c - Center of gravity of load	500 mm
1.9	y - Wheelbase	1860 mm
	Weight	
2.1	Weight of truck in working order	5900 kg
2.2	Laden weight on front/rear axle	3350 kg / 3850 kg
2.3	Unladen weight on front/rear axle	1900 kg / 4000 kg
	Wheels	
3.1	Tyre equipment: bandage (V), PPS (SE), inflatable tyre (L)	Cellular solid cushion
3.5	Number of front wheels (x)	2x / 2
	Dimensions	
4.1	α / β - Front/Rear mast angle	1.50 ° / 3.50 °
4.2	h1 - Height (mast lowered)	2810 mm
4.3	h2 - Free lift	1930 mm
4.4	h3 - Lift height (Duplex mast)	5550 mm
4.19	l1 - Total length	3890 mm
4.20	l2 - Length to fork heel	2740 mm
4.21	b1 - Overall width - Single/twinned wheels	1060 mm / -
4.22	e / s / l - Fork dimensions	1150 x 100 x 40
4.23	Fork carriage to DIN 15173 A/B	II B
4.24	b3 - Width of fork clamp	860 mm
4.33	Ast - Aisle width for 1000 x 1200 pallet widthwise	1700 mm
4.34	Ast - Aisle width for 800 x 1200 pallet lengthwise	1900 mm
	Performances	
5.1	Speed of travel laden / unladen	9 km/h / 9.50 km/h
5.2	Lifting speed laden / unladen	0.35 m/s / 0.45 m/s
5.3	Lowering speed laden / unladen	0.40 m/s / 0.35 m/s
5.7	Maximum ramp laden / unladen	8 % / 10.50 %
	Engine	
6.4	Battery voltage/capacity	48 V / 620 Ah
7.2	Useful power	10 kW
	Miscellaneous	
8.2	Working hydraulic pressure for attachments	200 bar
8.3	Oil flow rate for attachments	25 l/min
8.4	Measured/guaranteed mean noise level at the ear of the operator	73 dB(A)

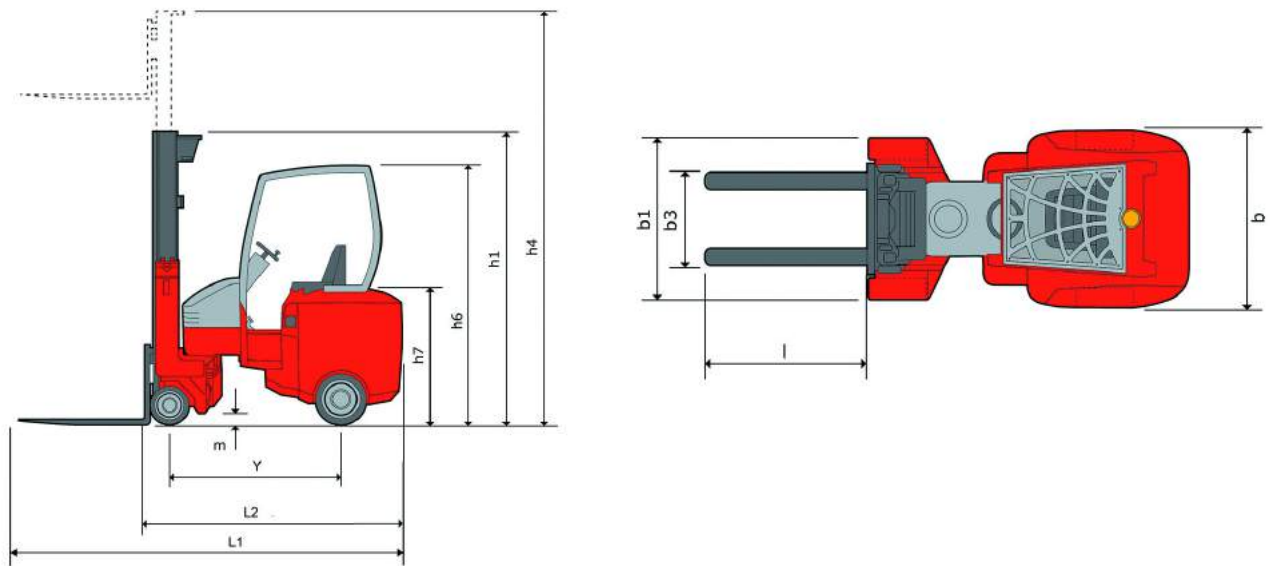

Characteristics of masts and residual capacities

Triplex Free Lift		4200	5010	5550	6000	6600	7620
Lift height	mm	4200	5010	5550	6000	6600	7620
Height (mast lowered)	mm	2360	2630	2810	2960	3210	3650
Free lift	mm	1400	1750	1930	2080	2330	2670
Height of extended mast	mm	5030	5910	6450	6900	7500	8520



Siège Social
430 rue de l'Aubinière - 44150 Ancenis Cedex - France
Tel: +33(0)2 40 09 10 11 - Fax: +33 (0)2 40 09 10 97
www.manitou.com



This brochure describes versions and configuration options for Manitou products which may be fitted with different equipment. The equipment described in this brochure may be standard, optional or not available depending on version. Manitou reserves the right to change the specifications shown and described at any time and without prior warning. The manufacturer is not liable for the specifications given. For more information, contact your Manitou dealer. Non-contractual document. Product descriptions may differ from actual products. List of specifications is not comprehensive. The logos and visual identity of the company are the property of Manitou and may not be used without authorisation. All rights reserved. The photos and diagrams contained in this brochure are provided for information only.

MANITOU BF SA - Limited company with board of directors - Share capital: 39,547,824 euros - 857 802 508 RCS Nantes