



ON-FORK HANDLING SOLUTIONS





Tilting Forks Carriage - MT & MLT (PFB)	10
Tilting Forks Carriage - MRT & MHT (PFB)	12
Floating Forks Carriage - MT & MLT (TFF)	14
Floating Forks Carriage - MRT & MHT (TFF)	16
360° rotating fork carriage (CAT-R)	18
Carriage - Floating Fork Carriage With Hydraulic Levelling (TFF CN) NEW	20
Carriage - Tilting and Slewing Fork Carriage (PFB +/-90°) NEW	20
Tilting Forks Carriage + Load Backrest (PFB LB)	21
Tilting Forks Carriage With Side Shift - MRT & MHT (PFB)	22
Tilting Forks Carriage + Side Shift (PFB SS)	24
Tilting Forks Carriage + Side Shift + Load backrest (PFB LB SS)	25
Hydraulic Floating Fork Positioner (CAF)	26
HD Floating Fork Positioners (TFF)	28
HD Fork Positioners (TFF)	30
Competitive Carriage Interface (IC)	32
Kerb Driver (PBA)	33
Wide Opening Fork Positioner (CAI-P)	34



TILTING FORK CARRIAGE - MT & MLT (PFB)



	PFB 20N 1020	PFB 25N 1020	PFB 25N 1260	PFB 35N 1260	PFB 35N 1470	PFB 35N 1580
Capacity (kg)	2000	2500		3500		
Width (mm)	1052	1026	1302		1512	1622
ISO/ FEM norm	2	2	2	3	3	3
Reference	"52558727 (2) 52000825	571958	571959	653744	653745	653746

Available fork dimensions (mm) FORKS ARE NOT INCLUDED IN THE PFB/ ORDER 2 FORKS!

100*40*1100		(1) 415689				
100*40*1200	415691					
125*45*1200		415835	415835	415618	415618	415618
125*50*1200						
200*60*1200						

Machine compatibility

MLT 625		x	x			
MLT 630 <i>NewAG</i>				x	x	x
MLT 635 <i>NewAG</i>				x	x	x
MLT 730 <i>NewAG</i>				x	x	x
MLT-X 732				x		
MLT 733 <i>NewAG</i>				x	x	x
MLT-X 735				x	x	x
MLT 737 <i>NewAG</i>						
MLT 741 <i>NewAG</i>						
MLT 840						
MLT 845						
MLT 940 <i>NewAG</i>						
MLT 961						
MLT-X 1035				x	x	x
MLT 1040						
MT 420	x					
MT 625		x	x			
MT 733 Easy				x	x	x
MT 933 Easy				x	x	x
MT 1033 Easy				x	x	x
MT 1135				x	x	
MT 1335				x	x	
MT 1440						
MT 1840						



- Efficient handling solution
- Forks compliant with FEM/ISO standard, forks' length according to model.
- Tilting forks.
- Load backrest: available on specific versions. Please see dedicated pages.
- (1): United Kingdom & Ireland only
- (2): for MT 420 with option "skid steer carriage" only

	PFB 45N 1260	PFB 45N 1670	PFB 45N 2000	PFB FEM4 1200	PFB 75MT 1750	PFB 75MT 2000
Capacity (kg)	4500			6000	7500	7500
Width (mm)	1286	1696	2026	1200	1834	2084
ISO/ FEM norm	4	4	4	4	4	4
Reference	654407	653747	653748	732330	504107	527216

Available fork dimensions (mm) FORKS ARE NOT INCLUDED IN THE PFB/ ORDER 2 FORKS!						
100*40*1100						
100*40*1200						
125*45*1200						
125*50*1200	415652	415652	415652			
200*60*1200				513110	513110	513110

Machine compatibility						
MLT 625						
MLT 630 <i>NewAG</i>						
MLT 635 <i>NewAG</i>						
MLT 730 <i>NewAG</i>						
MLT-X 732						
MLT 733 <i>NewAG</i>						
MLT-X 735						
MLT 737 <i>NewAG</i>	x	x	x			
MLT 741 <i>NewAG</i>	x	x	x			
MLT 840	x	x				
MLT 845	x	x	x			
MLT 940 <i>NewAG</i>	x	x	x			
MLT 961				x	x	x
MLT-X 1035						
MLT 1040	x	x				
MT 420						
MT 625						
MT 733 Easy						
MT 933 Easy						
MT 1033 Easy						
MT 1135						
MT 1335						
MT 1440	x	x	x			
MT 1840	x	x	x			

MANDATORY MACHINE EQUIPMENT: ✕



TILTING FORK CARRIAGE - MRT & MHT (PFB)



	PFB 1320		PFB 1750
Capacity (kg)	4500	5000	5000
Width (mm)	1320	1320	1750

Available fork dimensions (mm)							
Load backrest	No	No	No	No	Yes	Yes	Yes
120*50*1200	924877						
150*50*1200		921245	53009916	52576641	923864	921246	53010108
150*60*1200							
200*60*1200							
150*50*1500		921525			923865	921529	
200*60*1500							
150*60*1600							
200*60*2000							

Machine compatibility							
MRT Easy 1440	x	x			x	x	
MHT Easy 1640	x	x			x	x	
MHT Easy 1840	x	x			x	x	
MRT Easy 2150	x	x			x	x	
MRT Easy 2545	x	x			x	x	
MRT 2150		x			x	x	
MRT 2550		x			x	x	
MRT 2470		x (1)		x (2)			
MRT 3050		x (1)		x (2)			
MRT 3255			x				x
MHT 790							
MHT 1490							



- Efficient handling solution.
- Forks compliant with FEM/ISO standard, forks' length according to model.
- Tilting forks.
- (1): Not allowed for road circulation in Germany- ask your Manitou subsidiary.
- (2): Mandatory for road circulation in Germany- ask your Manitou subsidiary.

	PFB 2000	PFB 1320	PFB 1750	PFB 2000	PFB 1750	PFB 2000
Capacity (kg)	5000	7000	7000	7000	9000	9000
Width (mm)	2000	1320	1750	2000	1750	2000

Available fork dimensions (mm)

Load backrest	Yes	Yes	Yes	Yes	Yes	Yes		
120*50*1200								
150*50*1200	921247	53010112						
150*60*1200			52585460	52587815				
200*60*1200							939056	939058
150*50*1500	921533							
200*60*1500							53021960	53022163
150*60*1600					52581520	52581550		
200*60*2000							53025302	53025305

Machine compatibility

MRT Easy 1440								
MHT Easy 1640								
MHT Easy 1840								
MRT Easy 2150								
MRT Easy 2545								
MRT 2150	x							
MRT 2550	x							
MRT 2470			x (1)	x (2)	x (1)	x (1)		
MRT 3050								
MRT 3255		x						
MHT 790							x	x
MHT 1490							x	x

MANDATORY MACHINE EQUIPMENT: ✕



FLOATING FORK CARRIAGE - MT & MLT (TFF)



	TFF 29 MT	TFF 35 MT	
Capacity (kg)	2900	3500	
Width (mm)	1140	1140	1400
Max. fork spread (mm)	1040	1040	1300

Available fork dimensions (mm)			
Load backrest	Standard		
100*50*1070	(1) 52000328		
100*50*1200	(1) 788793		
140*40*1200	653340		
125*45*1200		654093	654094
125*50*1200			
200*60*1200			
200*60*1500			

Machine compatibility				
MLT 625	x	x		
MLT 630 <i>NewAg</i>			x	x
MLT 635 <i>NewAg</i>			x	x
MLT 730 <i>NewAg</i>			x	x
MLT-X 732			x	
MLT 733 <i>NewAg</i>			x	x
MLT-X 735			x	x
MLT 737 <i>NewAg</i>				
MLT 741 <i>NewAg</i>				
MLT 840				
MLT 845				
MLT 940 <i>NewAg</i>				
MLT 961				
MLT-X 1035			x	x
MLT 1040				
MT 420	x			
MT 625	x	x		
MT 733 Easy			x	x
MT 933 Easy			x	x
MT 1033 Easy			x	x
MT 1135			x	x
MT 1335			x	x
MT 1440				
MT 1840				



- Solution adapted to uneven ground: floating forks + levelling.
- Load backrest standard
- Fork levelling
- (1): United Kingdom & Ireland only

	TFF 45 MT		TFF 75 MT
Capacity (kg)	4500		7500
Width (mm)	1160	1420	1495
Max. fork spread (mm)	1040	1300	1430

Available fork dimensions (mm)			
Load backrest	Standard		
100*50*1070			
100*50*1200	788794		
140*40*1200			
125*45*1200			
125*50*1200	653344	653345	
200*60*1200			504280 + 2x 528083 504280 + 2x 578154

Machine compatibility			
MLT 625			
MLT 630 <i>NewAg</i>			
MLT 635 <i>NewAg</i>			
MLT 730 <i>NewAg</i>			
MLT-X 732			
MLT 733 <i>NewAg</i>			
MLT-X 735			
MLT 737 <i>NewAg</i>	x		x
MLT 741 <i>NewAg</i>	x		x
MLT 840	x		x
MLT 845	x		x
MLT 940 <i>NewAg</i>	x		x
MLT 961			x
MLT-X 1035			
MLT 1040	x		x
MT 420			
MT 625			
MT 733 Easy			
MT 933 Easy			
MT 1033 Easy			
MT 1135			
MT 1335			
MT 1440	x		x
MT 1840	x		x

MANDATORY MACHINE EQUIPMENT: ✕



FLOATING FORK CARRIAGE - MRT & MHT (TFF)



	TFF 4t		TFF 5t	
Capacity (kg)	4000	5000	5000	5000
Width (mm)	1030	1030	1300	1800

Available fork dimensions (mm)

Load backrest	Standard			
100*60*1200	(3) 923630	(3) 53027271	931267	(1) 53027260
100*60*1800			931266	(1) 53027259
100*60*2000	(1) 53027273			
125*50*1200	924857			
130*45*1200		(2) 53021451		
130*60*1200			939700	
150*60*1200	921238		921239	(1) 53027282
200*60*1200				
150*60*1500				
200*60*1500				
200*70*1200				
200*70*1500				
200*70*1800				
200*70*2400				
200*80*1200				
200*80*1800				
200*95*2400				
200*110*1800				
250*100*1800				
250*100*2400				
200*120*2400				

Machine compatibility

MRT Easy 1440	X							X
MRT Easy 1640	X							X
MRT Easy 1840	X							X
MRT Easy 2145	X							X
MRT Easy 2545	X							X
MRT 2150		X				X		X
MRT 2470			X		X		X	X
MRT 2550		X				X		X
MRT 3050			X	X	X		X	X
MRT 3255						X		
MHT 790								
MHT 1490								
MHT 10130								
MHT 10180								
MHT 10230								



- Solution adapted to uneven ground: floating forks+ leveling.
- Load backrest standard.
- Fork levelling.
- (1): Not allowed for road circulation in Germany on MRT 2470 & MRT 3050 - ask your Manitou subsidiary.
- (2): Mandatory for road circulation in Germany. An additional kit is mandatory. Please contact your Manitou dealer.
- (3): United Kingdom & Ireland only.

	TFF 5.5t	TFF 7t	TFF 9t	TFF 13t	TFF 18t	TFF 23t
Capacity (kg)	5500	7000	9000	13000	18000	23000
Width (mm)	1300	1030	1425 2000	1750 2500	1750 2500	2000 2500

Available fork dimensions (mm)

Load backrest	Standard					
100*60*1200						
100*60*1800						
100*60*2000						
125*50*1200						
130*45*1200						
130*60*1200	932152	(2) 53022260				
150*60*1200						
200*60*1200			939800 939347			
200*60*1500			939345 939348			
200*60*1500			939346 939349			
200*70*1200				53005668 53009230		
200*70*1500				939200 939203		
200*70*1800				939201 939204		
200*70*2400				939202 939205		
200*80*1200					53010961 53010955	
200*80*1800					53010960 53010953	
200*95*2400					53010930 53010920	
200*110*1800						53011386 53009458
250*100*1800						53011384 53009741
250*100*2400						53011379 53009739
200*120*2400						53009560 53009260

Machine compatibility

MRT Easy 1440						
MRT Easy 1640						
MRT Easy 1840						
MRT Easy 2145						
MRT Easy 2545						
MRT 2150						
MRT 2470		X				
MRT 2550						
MRT 3050						
MRT 3255	X					
MHT 790			X	X		
MHT 1490			X	X		
MHT 10130				X	X	
MHT 10180					X	X
MHT 10230						X

MANDATORY MACHINE EQUIPMENT: ✕



360° ROTATING FORK CARRIAGE



- Major increase of your MRT's functionality that's to a continuous 360° fork rotation.
- 2 capacities: 4000kg frontal (+- 15°) and 2500kg rotated.
- Safety: constant monitoring of the load's weight, angle & position; adaptive overload control according to the load's position; no forward tilting if rotation > 120° and boom lifted over 3m high.
- Lower fuel consumption: limits machine movements & manoeuvres.



Easy handling of long loads in narrow spaces

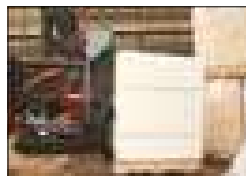

Lightens load placement on the construction site

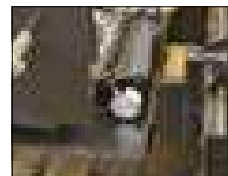

Adaptive overload control according to the load's position



* MRT St4 "S2" and upward - For all previous machines
Please contact your MANITOU dealer

	CAT 1200 / 4000 R
Max. capacity- frontal (15°/15°) (kg)	4000
Max. capacity- rotated (360°) (kg)	2500
Width (mm)	1290
Height (mm)	1193
Fork length (mm)	1200 (ISO)
Weight (kg)	730

Machine compatibility

Reference	53026525
MRT 2150 St4 *	x
MRT 2470 St4	x
MRT 2550 St4 *	x
MRT 3050 St4	x

MANDATORY MACHINE EQUIPMENT: 



CARRIAGE

FLOATING FORK CARRIAGE WITH HYDRAULIC LEVELLING - TFF CN

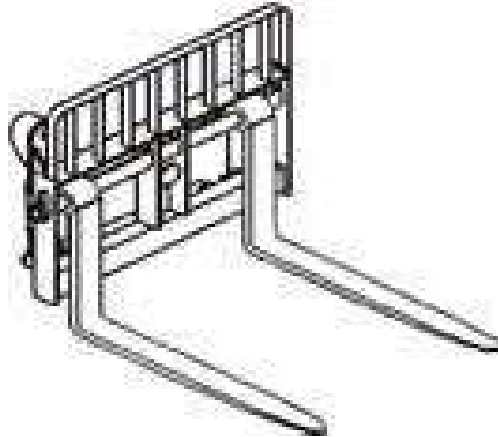

- Easy pallet collection & placement with the hydraulic carriage levelling.
- Pin-type forks 150x60x1200mm.
- Capacity 5t, max. fork spread 1180 (external fork edges).
- Available on MRT Easy, MRT 2150 & 2550, MRT 3255 (ref. 921240).

MANDATORY MACHINE EQUIPMENT:



CARRIAGE

TILTING AND SLEWING FORK CARRIAGE - PFB +/-90°

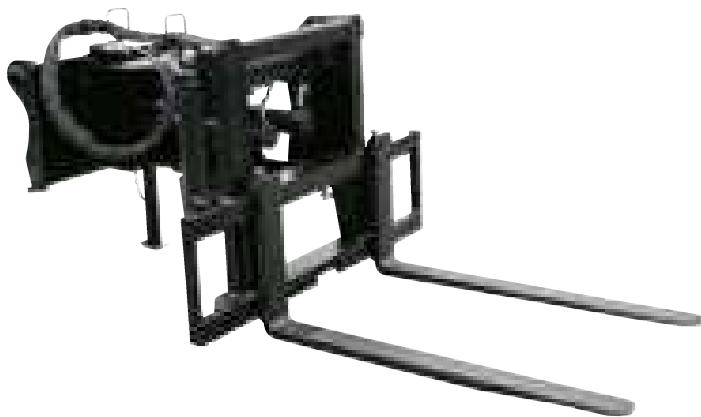

- Increase load placement efficiency thanks to this 90°/90° fork carriage.
- ISO forks 100x45x1200mm.
- Straight & rotated capacity 1500kg.
- Width: 1320mm.
- Available on MRT Privilege+ (ref. 923348).

MANDATORY MACHINE EQUIPMENT:



TILTING FORK CARRIAGE + LOAD BACKREST



- Load backrests stabilize palletized loads during transport.
- Especially useful for high pallets.
- Load backrests bolted on «PFB» tilting fork carriages.
- Note: to be used with FEM forks.

	PFB 25N 1020 LB	PFB 25N 1260 LB	PFB 35N 1260 LB	PFB 35N 1470 LB	PFB 45N 1670 LB	PFB 45N 2000 LB
Capacity (kg)	2500	2500	3500	3500	4500	4500
Width (mm)	1070	1310	1310	1520	1810	2140
Height (mm)	1176	1188	1185	1185	1209	1209
Weight (kg)	105	118	130	158	310	360

Machine compatibility

Reference	52000198	52000199	52000200	52000201	52000202	52000203
MLT 625	x	x				
MLT 630 <i>NewAG</i>			x	x		
MLT 635 <i>NewAG</i>			x	x		
MLT 730 <i>NewAG</i>			x	x		
MLT 733 <i>NewAG</i>			x	x		
MLT-X 735			x	x		
MLT 737 <i>NewAG</i>					x	x
MLT 741 <i>NewAG</i>					x	x
MLT 840					x	x
MLT 940 <i>NewAG</i>					x	x
MT 625	x	x				
MT 733 Easy			x	x		
MT 933 Easy			x	x		
MT 1033 Easy			x	x		
MT 1135			x	x		
MT 1335			x	x		
MT 1440					x	x
MT 1840					x	x

MANDATORY MACHINE EQUIPMENT: ✕



TILTING FORK CARRIAGE WITH SIDE SHIFT - MRT & MHT

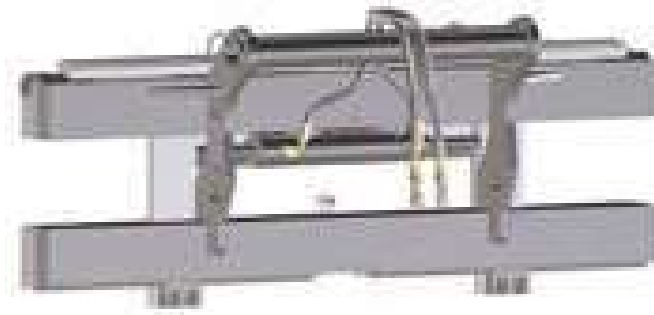

	PFB 1320		PFB 1750
Capacity (kg)	4500	4900	4900
Width (mm)	1320	1320	2000

Available fork dimensions (mm)						
Load backrest	No	No	No	Yes	Yes	Yes
120*50*1200	924878	921241		923858		
150*50*1200			53010106		921242	53010110
200*60*1200						
150*50*1500		921513		923859	921517	
200*60*1500						
200*60*2000						

Machine compatibility						
MRT Easy 1440	x					
MHT Easy 1640	x					
MHT Easy 1840	x					
MRT Easy 2145	x					
MRT Easy 2545	x					
MRT 2150		x		x	x	
MRT 2550		x		x	x	
MRT 2470		x (1)		x (1)	x (1)	
MRT 3050		x (1)		x (1)	x (1)	
MRT 3255			x			x
MHT 790						
MHT 1490						



- Efficient handling solution.
- Tilting forks compliant with FEM standard, forks' length according to model.
- Constant side shift
- (1): Not allowed for road circulation in Germany- ask your Manitou dealer.

	PFB 2000	PFB 1750	PFB 2000
Capacity (kg)	4900	9000	9000
Width (mm)	2000	1750	2000

Available fork dimensions (mm)				
Load backrest	Yes	Yes	Yes	Yes
120*50*1200				
150*50*1200	921243	53010114		
200*60*1200			939057	939059
150*50*1500	921521			
200*60*1500			53025304	53025306
200*60*2000			53025303	53025307

Machine compatibility				
MRT Easy 1440				
MHT Easy 1640				
MHT Easy 1840				
MRT Easy 2145				
MRT Easy 2545				
MRT 2150	x			
MRT 2550	x			
MRT 2470	x (1)			
MRT 3050	x (1)			
MRT 3255		x		
MHT 790			x	x
MHT 1490			x	x

MANDATORY MACHINE EQUIPMENT: 



TILTING FORK CARRIAGE + SIDE SHIFT

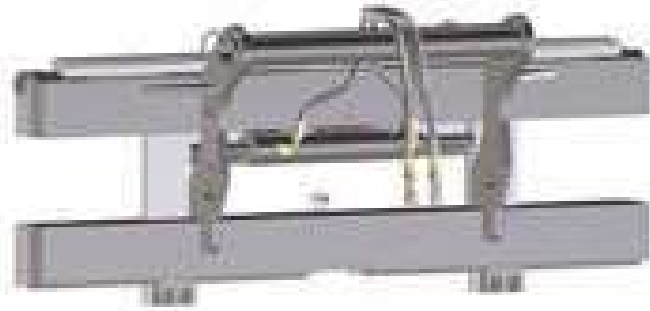

- Tilting fork carriage with hydraulic side shift for efficient load placement operations.
- Guarantees an accurate and efficient positioning of the handled palets.
- Note: to be used with FEM forks.

	PFB 25N 1020 SS	PFB 25N 1260 SS	PFB 35N 1260 SS	PFB 35N 1580 SS	PFB 45N 1670 SS
Capacity (kg)	2500	2500	3500	3500	4500
Width (mm)	1070	1310	1310	1580	1696
Height (mm)	553	554	658	658	666
Side shift (mm)	100/100	100/100	100/100	100/100	100/100
Weight (kg)	135	145	175	300	530

Machine compatibility

Reference	52000099	52000100	52000101	52000102	52000103
MLT 625	x	x			
MLT 733 <i>NewAg</i>			x		
MT 625	x	x			
MT 733 Easy			x	x	
MT 933 Easy			x	x	
MT 1033 Easy			x	x	
MT 1135			x	x	
MT 1335			x	x	
MT 1440					x
MT 1840					x

MANDATORY MACHINE EQUIPMENT:



TILTING FORK CARRIAGE + SIDE SHIFT + LOAD BACKREST



- Tilting fork carriage with hydraulic side shift and load backrest for efficient high/bulky load placement.
- Guarantees an accurate and efficient positioning of the handled palets.
- Bolt-on load backrest for a higher load stability.
- Note: to be used with FEM forks.

	PFB 25N 1020 SS LB	PFB 35N 1260 SS LB	PFB 45N 1670 SS LB
Capacity (kg)	2500	3500	4500
Width (mm)	1044	1310	1810
Height (mm)	1222	1229	1258
Side shift (mm)	100/100	100/100	100/100
Weight (kg)	170	210	585

Machine compatibility			
Reference	52000204	52000205	52000206
MT 625	x		
MT 733 Easy		x	
MT 933 Easy		x	
MT 1033 Easy		x	
MT 1135		x	
MT 1335		x	
MT 1440			x
MT 1840			x

MANDATORY MACHINE EQUIPMENT:



HYDRAULIC FLOATING FORK POSITIONER

- Increases the efficiency of pallet handling and saves time.
- Accurate fork spread adaptation to suit all pallets.
- Floating forks with levelling capacity for rough terrain applications.
- Fork spread: 1010 mm / 275 mm (middle of the forks).





Floating forks with levelling



Fork travel lock

	CAF 1260 / 4500 P
Capacity (kg)	4500
Fork spread (mm)	275 / 1010
Weight (kg)	351

Machine compatibility	
Reference	52000273
MT 625	x
MT 733 Easy	x
MT 933 Easy	x
MT 1033 Easy	x
MT 1135	x
MT 1335	x
MT 1440	x
MT 1840	x

MANDATORY MACHINE EQUIPMENT: 



HD FLOATING FORK POSITIONERS



- Increases the efficiency of on-forks handling applications.
- Accurate and effortless fork spread adaptation from the cab.
- (1): Optional constant side shift for even more efficiency.
- Real rough-terrain attachment- innovative design & maximum component protection.
- Floating forks for more efficiency on uneven grounds.



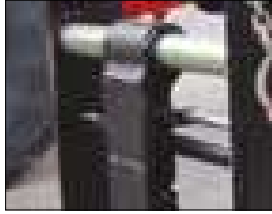

Fork positioning using sliders- forks keep floating



Limited thickness & increased visibility



Patented side shifting system (optional) using chromed rods

* According to fork length

(1) : Option «2 hydraulic functions on the top of the boom» required

	TFF + positioner 9t 2000mm	TFF + positioner + side shift 9t 2000mm (1)	TFF + positioner 9t 2500mm	TFF + positioner + side shift 9t 2500mm (1)	TFF + positioner 13t 2500mm	TFF + positioner + side shift 13t 2500mm (1)
Capacity (kg)	9000 @ 600mm	9000@ 600mm	9000 @ 600mm	9000 @ 600mm	13000 @ 600mm	13000 @ 600mm
Width (mm)	2000	2000	2500	2500	2500	2500
Lenght (mm)	1200 - 2000	1200 - 2000	1200 - 2000	1200 - 2000	1800 - 2400	1800 - 2400
Fork spread (mm)	400 - 1695	401 - 1696	788 - 2152	800 - 2195	788 - 2152	788 - 2152
Side shift (mm)		200 / 200		200 / 200		200 / 200
Weight (kg)	980*	1110*	1090*	1255*	1420*	1935*

Available fork dimensions						
200x60x1200mm	939350	939352	939355	939357		
200x60x1500mm	939351	939055	939356	53004234		
200x70x1500mm					939219	939221
200x60x1800mm	939054	939353	939216	939358		
200x70x1800mm					939220	939222
200x60x2000mm	53009730	939354	53006760	939359		
200x70x2400mm					53008986	53008727

Machine compatibility						
MHT 790	x	x	x	x		
MHT 1490	x	x	x	x		
MHT 10130					x	x

(1) MANDATORY MACHINE EQUIPMENT: 2 x 



HD FORK POSITIONERS

- Increases the efficiency of on-forks handling applications.
- Accurate and effortless fork spread adaptation from the cab.
- (1): Optional integrated side shift for even more efficiency.
- Real rough-terrain attachment- innovative design & maximum component protection.



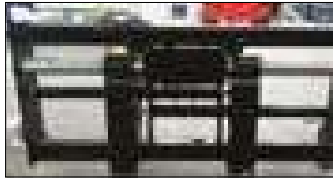

Limited thickness & increased visibility



Increased cylinder rigidity for a longer life in harsh rough-terrain conditions



Safety: stabilizer for yard storage

*According to fork length & width

(1): Option «2 hydraulic functions on the top of the boom» required

	TFF + positioner 18t 2500mm	TFF + positioner + side shift 18t 2500mm (1)	TFF + positioner 23t 2500mm	TFF + positioner + side shift 23t 2500mm (1)
Capacity (kg)	18000@600mm 14000@1200mm	18000@600mm 14000@1200mm	23000@900mm 20000@1200mm	23000@900mm 20000@1200mm
Width (mm)	2500	2500	2500	2500
Lenght (mm)	1200 - 2400	1200 - 2400	1800 - 2400	1800 - 2400
Fork spread (mm)	815 - 2135	815 - 2135	815 - 2135	815 - 2135
Side shift (mm)		Variable		Variable
Weight (kg)	1475*	1475*	2410*	2410*

Available fork dimensions

200x80x1200mm	939301	53010976		
200x80x1800mm	939302	53010971		
200x110x1800mm			939320	53010999
250x100x1800mm			939321	53010994
200x95x2400	53011460	53010702		
200x120x2400mm			53011440	53009800
250x100x2400mm			939322	53010986

Machine compatibility

MHT 10180	x	x		
MHT 10230			x	x

(1) MANDATORY MACHINE EQUIPMENT: 2 x



COMPETITIVE CARRIAGE INTERFACE

- Allows the use of attachments with competitive brackets on standard MANITOU machines (MANITOU carriage).
- Note: specific safety rules apply, contact your MANITOU dealer.



	IC-JCB
Capacity (kg)	4100
Forward reach / depth (mm)	330
Carriage type	JCB®
Empty weight (kg)	155

Machine compatibility	
Reference	52000231
MLT 630 <i>NewAG</i>	x
MLT 635 <i>NewAG</i>	x
MLT 730 <i>NewAG</i>	x
MLT-X 735	x
MLT 737 <i>NewAG</i>	x
MLT 741 <i>NewAG</i>	x
MLT 840	x
MLA-T 533	x

MANDATORY MACHINE EQUIPMENT: ✕



KERB DRIVER



- Major improvement of kerb stone placing operations.
- Replaces human efforts with effortless vacuum power- strongly reduces workers' backache.
- «Bike-type» steering & 3.4m placing reach for a high productivity.
- Safety: vacuum accumulator prevents kerb brutal fall.

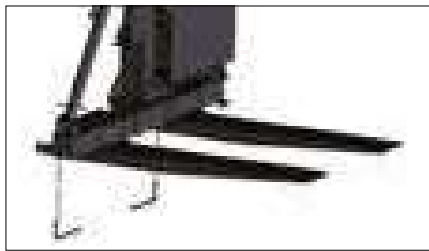

2 in 1 fork sleeves: can be used to transport the kerb stone pallet

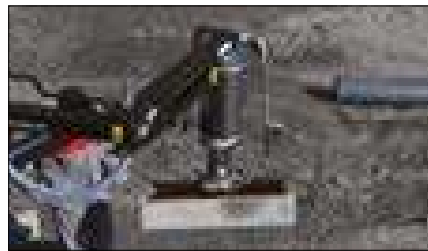

Effortless kerb lifting & placement

	PBA 25N 1020 LB
Capacity (kg)	1500
Hook capacity (kg)	160
Width (mm)	1619
Height (mm)	2512
Forward reach / depth (mm)	3,4
Empty weight (kg)	450

Machine compatibility	
Reference	790523
MT 1440	x
MT 1840	

MANDATORY MACHINE EQUIPMENT:



WIDE OPENING FORK POSITIONER



- Wide opening for more efficiency during wide pallet handling.
- Very good visibility thanks to a reviewed frame structure and an efficient component placement.
- Very efficient fork synchronisation using a dedicated hydraulic valve.
- MANITOU attachment: perfect integration on the forklift truck.
Note: this attachment is not designed for load clamping.

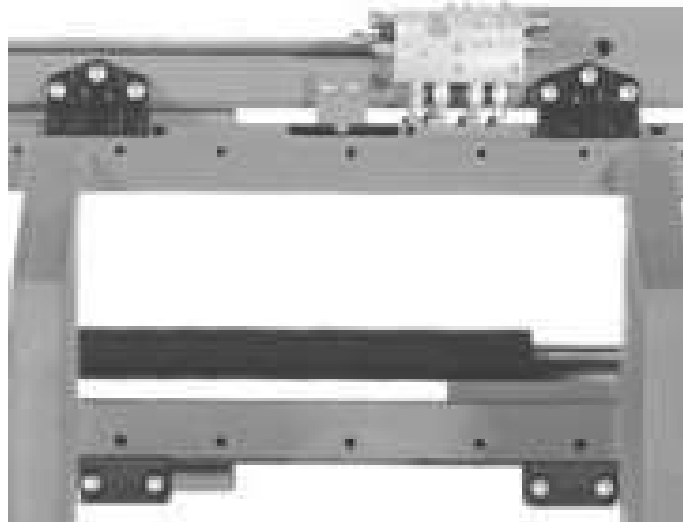

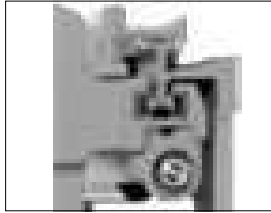

"Double T" main frame profile for even more resistance

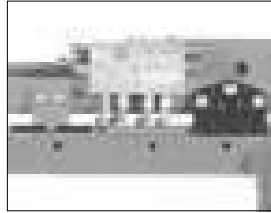

Hydraulic valve placed on the back of the frame- visibility & protection

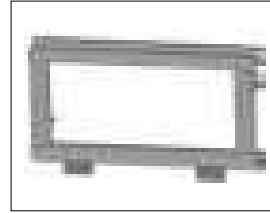

Industrial-clamp-type frame- increased rigidity & resistance



	CAI 1680 / 2500 P	CAI 1720 / 2800 P
Capacity (kg)	2500	2800
Thickness (mm)	157	182
Height (kg)	627	733
Fork spread (mm)	560/1680	560/1720
Side shift (mm)	No	No
Weight (kg)	193	233

Machine compatibility		
Reference	52531185	52531186
MI 15 D/G	x	
MI 18 D/G	x	
MI 20 D/G	x	
MI 25 D/G	x	
MI 30 D/G		x
MI 35 D/G		x

MANDATORY MACHINE EQUIPMENT:



E-Reco, an attachment recognition system for greater simplicity













Manitou is offering, as standard, the attachment-recognition system on its new-generation of rotary telescopic trucks MRT EASY and MRT PRIVILEGE +.

The system uses RFID radio-identification technology, very widely used in industry and retail.

This autonomous technique can remotely recover and record data. The machine detects the attachment at the head of the boom, analyses its data and directly proposes the corresponding working configuration (working envelope + movement speed + safety).

This technology provides the load chart in real time, taking into account the rotation angle of the turret and the position of the machine's stabilisers and in accordance with the mobile crane standard.

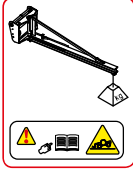
TABLE SYMBOL

	No predisposition required
	Hydraulic line
	Return piping to hydraulic oil tank
	Electric predisposition
	Platform predisposition
	Tyre handler, cylinder handler predisposition
	Please contact your Manitou subsidiary (special solution request required)
	Round bale
	Square bale
	Wrapped bale
	Suspended load : read user manual
	Machine equipped with attachment recognition system



Agriculture



Construction



Industry