

Technical sheet

EMA II 17

Warehousing Equipment



	Technical characteristics	Metric
1.1	Manufacturer	Manitou
1.2	Model	EMA II 17
1.3	Type of traction	Electric
1.4	Type of operation	Seated
1.5	Q - Rated capacity	1700 kg
1.6	c - Center of gravity of load	500 mm
1.9	y - Wheelbase	1745 mm
	Weight	
2.1	Weight of truck in working order	6000 kg
2.2	Laden weight on front/rear axle	4250 kg / 3250 kg
2.3	Unladen weight on front/rear axle	2000 kg / 4000 kg
	Wheels	
3.1	Tyre equipment: bandage (V), PPS (SE), inflatable tyre (L)	Cellular solid cushion
3.5	Number of front wheels (x)	2x / 2
	Dimensions	
4.1	α / β - Front/Rear mast angle	1.50 ° / 3.50 °
4.2	h1 - Height (mast lowered)	2750 mm
4.3	h2 - Free lift	1930 mm
4.4	h3 - Lift height (Duplex mast)	5550 mm
4.5	h4 - Height of extended mast	6380 mm
4.19	l1 - Total length	3710 mm
4.20	l2 - Length to fork heel	2560 mm
4.22	e / s / l - Fork dimensions	1150 x 100 x 40
4.24	b3 - Width of fork clamp	860 mm
4.33	Ast - Aisle width for 1000 x 1200 pallet widthwise	1800 mm
4.34	Ast - Aisle width for 800 x 1200 pallet lengthwise	2000 mm
	Performances	
5.1	Speed of travel laden / unladen	9 km/h / 9.50 km/h
5.2	Lifting speed laden / unladen	0.35 m/s / 0.45 m/s
5.3	Lowering speed laden / unladen	0.40 m/s / 0.36 m/s
5.7	Maximum ramp laden / unladen	8 % / 10.50 %
5.10	Service brake	Hydraulic
	Engine	
6.4	Battery voltage/capacity	48 V / 620 Ah
7.2	Useful power	10 kW
	Miscellaneous	
8.2	Working hydraulic pressure for attachments	200 bar
8.3	Oil flow rate for attachments	25 l/min
8.4	Measured/guaranteed mean noise level at the ear of the operator	73 dB(A)

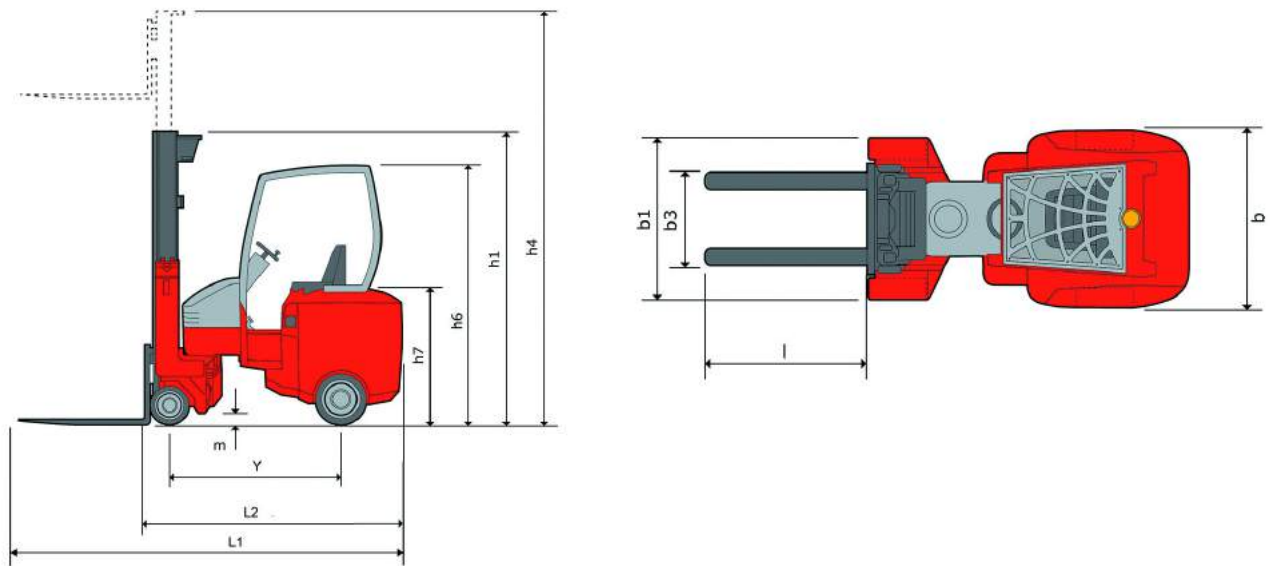

Characteristics of masts and residual capacities

Triplex Free Lift		4200	4620	4800	5010	5220	5550	6000	6600	7200	7620
Lift height	mm	4200	4620	4800	5010	5220	5550	6000	6600	7200	7620
Height (mast lowered)	mm	2300	2440	2500	2570	2640	2750	2900	3150	3400	3590
Free lift	mm	1480	1620	1680	1750	1820	1930	2080	2330	2580	2770
Height of extended mast	mm	5030	5450	5630	5840	6050	6380	6830	7430	8030	8450



Siège Social
430 rue de l'Aubinière - 44150 Ancenis Cedex - France
Tel: +33(0)2 40 09 10 11 - Fax: +33 (0)2 40 09 10 97
www.manitou.com



This brochure describes versions and configuration options for Manitou products which may be fitted with different equipment. The equipment described in this brochure may be standard, optional or not available depending on version. Manitou reserves the right to change the specifications shown and described at any time and without prior warning. The manufacturer is not liable for the specifications given. For more information, contact your Manitou dealer. Non-contractual document. Product descriptions may differ from actual products. List of specifications is not comprehensive. The logos and visual identity of the company are the property of Manitou and may not be used without authorisation. All rights reserved. The photos and diagrams contained in this brochure are provided for information only.

MANITOU BF SA - Limited company with board of directors - Share capital: 39,547,824 euros - 857 802 508 RCS Nantes